

HX500S

Payload 500Kgf

Installation method		Application	
Floor		Spot welding	●
Ceiling		Arc welding	
Wall surface		Handling	●
Shelf	●	Assembly	
		Sealing	●
		Painting	

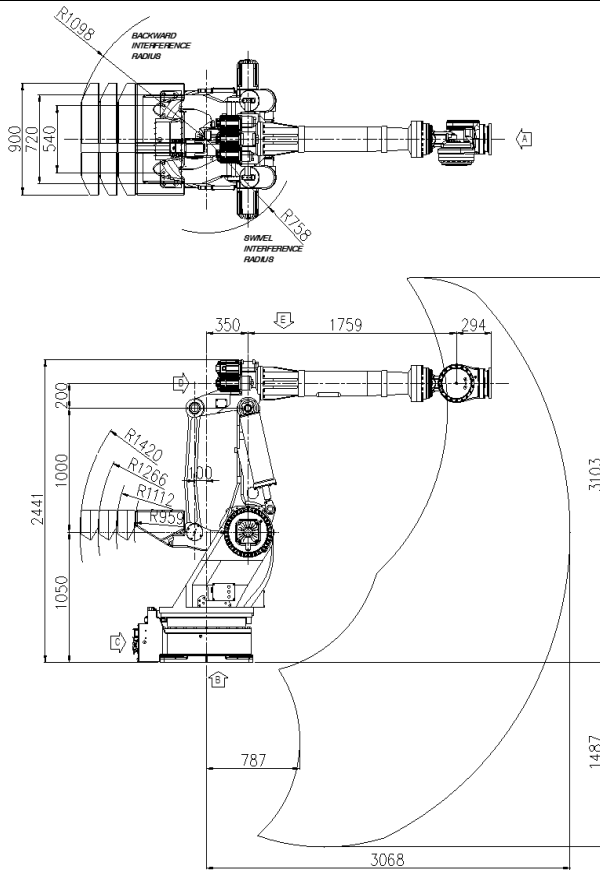

View A: Detailed drawing of the wrist attachment part

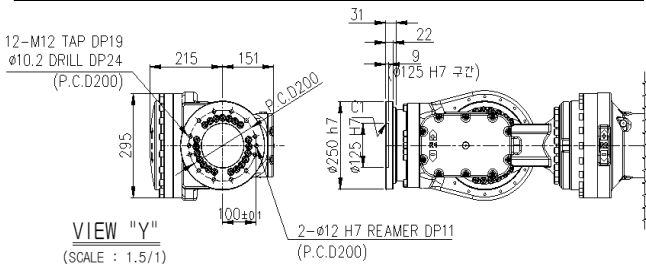

View B: Dimensional drawing for the floor installation of the body

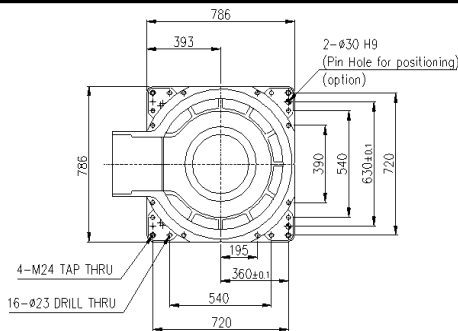

Wrist-axis torque line diagram

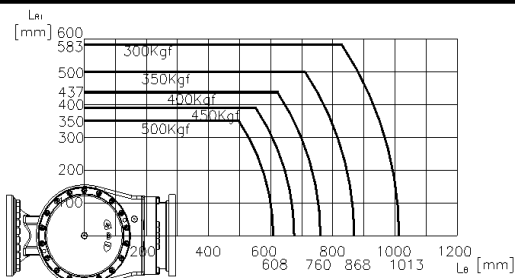

Item		Specifications	
Robot model		HX500S	
Payload		500 Kg	
Structure		Articulated	
Degree of freedom		6 axes	
Drive system		AC SERVO MOTOR	
Max. working envelope	Arm	S Swivel	±3.14 rad (±180°)
		H Horizontal	+1.65 ~ -0.87 rad (+95° ~ -50°)
		V Vertical	+1.04 ~ -1.04 rad (+60° ~ -60°)
	Wrist	R2 Rotation 2	±6.28 rad (±360°)
		B Bending	±2.09 rad (±120°)
Max. working speed	Arm	S Swivel	1.22 rad / s (70° / s)
		H Horizontal	1.22 rad / s (70° / s)
		V Vertical	1.22 rad / s (70° / s)
	Wrist	R2 Rotation 2	1.39 rad / s (80° / s)
		B Bending	1.39 rad / s (80° / s)
Wrist torque	R2 Rotation 2	2,984 N.m (304 Kgf.m)	
	B Bending	2,984 N.m (304 Kgf.m)	
	R1 Rotation 1	1,716 N.m (175 Kgf.m)	
	R1 Rotation 1	1,716 N.m (175 Kgf.m)	
Accuracy of position repeatability		±0.08 mm	
Ambient Temperature		0 ~ 45 °C (273 ~ 318 K)	
Robot's Weight		3,240 Kg	

View C: Application cable connection part (Option)

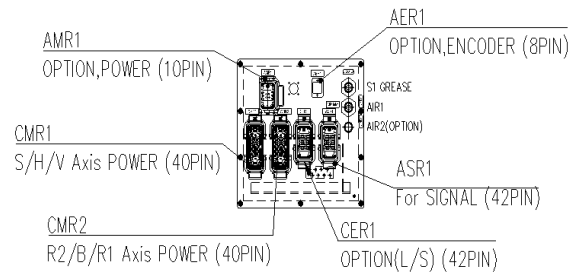

View D: Application cable connection part (Option)

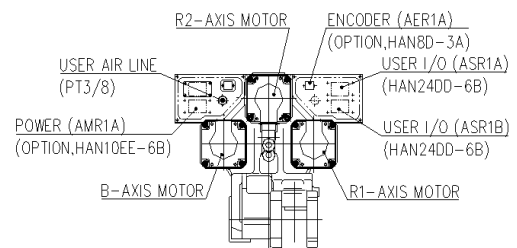

View E: Details of the application ancillary part attachment

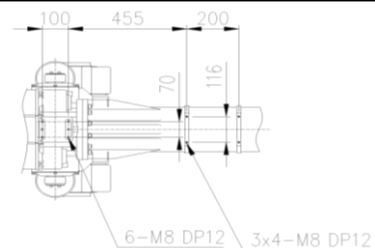

** For product improvement, some of the ratings, specifications, dimensions, etc. are subject to changes without notice.